

SA (1/4" Steel Shank)

Carbide Rotary Files - Cylindrical Shape

Submicron Grain Carbide

A - Aluminum Cut

D - Double Cut

* - Solid Carbide

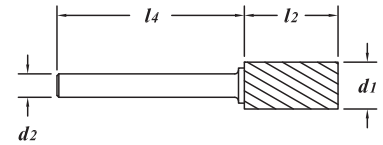

EDP#	TOOL #	$d1$ †		$d2$ Shank Diameter	$l2$ Flute Length	$l4$ Shank Length	1-11	12-24	25-49	50-100	
		Decimal	Diameter Metric								
60010	* SA-14	.1875	3/16"	4.763	1/4"	5/8"	1-3/8"	9.94	9.50	9.07	8.64
60012	* SA-14D	.1875	3/16"	4.763	1/4"	5/8"	1-3/8"	9.94	9.50	9.07	8.64
60020	* SA-1	.2500	1/4"	6.350	1/4"	5/8"	1-3/8"	8.84	8.46	8.07	7.69
60021	* SA-1A	.2500	1/4"	6.350	1/4"	5/8"	1-3/8"	11.10	10.62	10.13	9.65
60022	* SA-1D	.2500	1/4"	6.350	1/4"	5/8"	1-3/8"	8.84	8.46	8.07	7.69
60030	SA-2	.3125	5/16"	7.938	1/4"	3/4"	1-3/4"	12.35	11.81	11.28	10.74
60032	SA-2D	.3125	5/16"	7.938	1/4"	3/4"	1-3/4"	12.35	11.81	11.28	10.74
60040	SA-3	.3750	3/8"	9.525	1/4"	3/4"	1-3/4"	13.32	12.74	12.16	11.58
60041	SA-3A	.3750	3/8"	9.525	1/4"	3/4"	1-3/4"	17.92	17.14	16.36	15.58
60042	SA-3D	.3750	3/8"	9.525	1/4"	3/4"	1-3/4"	13.32	12.74	12.16	11.58
60050	SA-4	.4375	7/16"	11.113	1/4"	1"	1-3/4"	18.38	17.58	16.78	15.98
60052	SA-4D	.4375	7/16"	11.113	1/4"	1"	1-3/4"	18.38	17.58	16.78	15.98
60060	SA-5	.5000	1/2"	12.700	1/4"	1"	1-3/4"	19.62	18.77	17.91	17.06
60061	SA-5A	.5000	1/2"	12.700	1/4"	1"	1-3/4"	25.42	24.31	23.21	22.10
60062	SA-5D	.5000	1/2"	12.700	1/4"	1"	1-3/4"	19.62	18.77	17.91	17.06
60070	SA-6	.6250	5/8"	15.875	1/4"	1"	1-3/4"	23.76	22.73	21.69	20.66
60071	SA-6A	.6250	5/8"	15.875	1/4"	1"	1-3/4"	39.82	38.09	36.36	34.63
60072	SA-6D	.6250	5/8"	15.875	1/4"	1"	1-3/4"	23.76	22.73	21.69	20.66
60080	SA-7	.7500	3/4"	19.050	1/4"	1"	1-3/4"	37.62	35.98	34.35	32.71
60081	SA-7A	.7500	3/4"	19.050	1/4"	1"	1-3/4"	45.13	43.16	41.20	39.24
60082	SA-7D	.7500	3/4"	19.050	1/4"	1"	1-3/4"	37.62	35.98	34.35	32.71
60090	SA-9	1.000	1"	25.400	1/4"	1"	1-3/4"	51.31	49.08	46.85	44.62
60091	SA-9A	1.000	1"	25.400	1/4"	1"	1-3/4"	61.54	58.86	56.19	53.51
60092	SA-9D	1.000	1"	25.400	1/4"	1"	1-3/4"	51.31	49.08	46.85	44.62

Basic Rotary File Cut Styles Available

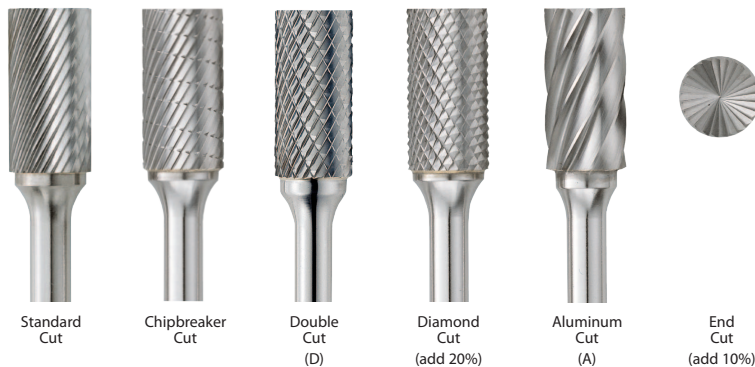

Double Cut and Aluminum Cut rotary files are in stock where indicated by (D) and (A) in the catalog tables.

Carbide Rotary Files - Cylindrical-Radius Shape

Submicron Grain Carbide

A - Aluminum Cut

D - Double Cut

* - Solid Carbide

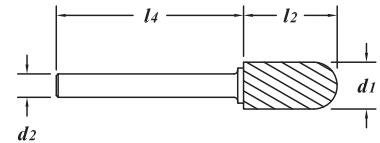

EDP#	TOOL #	$d1$ † Diameter		$d2$ Shank Diameter	$l2$ Flute Length	$l4$ Shank Length	1-11	12-24	25-49	50-100	
		Decimal	Metric								
61010	* SC-14	.1875	3/16"	4.763	1/4"	5/8"	1-3/8"	11.25	10.76	10.27	9.78
61012	* SC-14D	.1875	3/16"	4.763	1/4"	5/8"	1-3/8"	11.25	10.76	10.27	9.78
61020	* SC-1	.2500	1/4"	6.350	1/4"	5/8"	1-3/8"	10.58	10.12	9.66	9.20
61021	* SC-1A	.2500	1/4"	6.350	1/4"	5/8"	1-3/8"	13.97	13.37	12.76	12.15
61022	* SC-1D	.2500	1/4"	6.350	1/4"	5/8"	1-3/8"	10.58	10.12	9.66	9.20
61030	SC-2	.3125	5/16"	7.938	1/4"	3/4"	1-3/4"	12.35	11.81	11.28	10.74
61032	SC-2D	.3125	5/16"	7.938	1/4"	3/4"	1-3/4"	12.35	11.81	11.28	10.74
61040	SC-3	.3750	3/8"	9.525	1/4"	3/4"	1-3/4"	14.42	13.79	13.17	12.54
61041	SC-3A	.3750	3/8"	9.525	1/4"	3/4"	1-3/4"	25.00	23.91	22.83	21.74
61042	SC-3D	.3750	3/8"	9.525	1/4"	3/4"	1-3/4"	14.42	13.79	13.17	12.54
61050	SC-4	.4375	7/16"	11.113	1/4"	1"	1-3/4"	20.86	19.95	19.05	18.14
61052	SC-4D	.4375	7/16"	11.113	1/4"	1"	1-3/4"	20.86	19.95	19.05	18.14
61060	SC-5	.5000	1/2"	12.700	1/4"	1"	1-3/4"	21.62	20.68	19.74	18.80
61061	SC-5A	.5000	1/2"	12.700	1/4"	1"	1-3/4"	32.87	31.44	30.01	28.58
61062	SC-5D	.5000	1/2"	12.700	1/4"	1"	1-3/4"	21.62	20.68	19.74	18.80
61070	SC-6	.6250	5/8"	15.875	1/4"	1"	1-3/4"	28.88	27.62	26.37	25.11
61071	SC-6A	.6250	5/8"	15.875	1/4"	1"	1-3/4"	45.02	43.07	41.11	39.15
61072	SC-6D	.6250	5/8"	15.875	1/4"	1"	1-3/4"	28.88	27.62	26.37	25.11
61080	SC-7	.7500	3/4"	19.050	1/4"	1"	1-3/4"	42.49	40.65	38.80	36.95
61081	SC-7A	.7500	3/4"	19.050	1/4"	1"	1-3/4"	62.50	59.79	57.07	54.35
61082	SC-7D	.7500	3/4"	19.050	1/4"	1"	1-3/4"	42.49	40.65	38.80	36.95

SD (1/4" Steel Shank)

Carbide Rotary Files - Ball Shape

Submicron Grain Carbide

A - Aluminum Cut

D - Double Cut

* - Solid Carbide

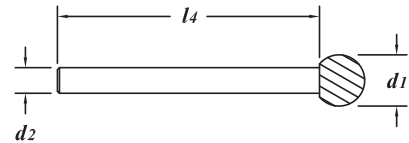

EDP#	TOOL #	$d1$ † Diameter		$d2$ Shank Diameter	$l2$ Flute Length	$l4$ Shank Length	1-11	12-24	25-49	50-100	
		Decimal	Metric								
62010	* SD-14	.1875	3/16"	4.763	1/4"	-	2"	11.25	10.76	10.27	9.78
62012	* SD-14D	.1875	3/16"	4.763	1/4"	-	2"	11.25	10.76	10.27	9.78
62020	* SD-1	.2500	1/4"	6.350	1/4"	-	2"	11.25	10.76	10.27	9.78
62021	* SD-1A	.2500	1/4"	6.350	1/4"	-	2"	17.83	17.05	16.28	15.50
62022	* SD-1D	.2500	1/4"	6.350	1/4"	-	2"	11.25	10.76	10.27	9.78
62030	SD-2	.3125	5/16"	7.938	1/4"	-	1-3/4"	10.58	10.12	9.66	9.20
62032	SD-2D	.3125	5/16"	7.938	1/4"	-	1-3/4"	10.58	10.12	9.66	9.20
62040	SD-3	.3750	3/8"	9.525	1/4"	-	1-3/4"	11.48	10.98	10.48	9.98
62041	SD-3A	.3750	3/8"	9.525	1/4"	-	1-3/4"	18.57	17.77	16.96	16.15
62042	SD-3D	.3750	3/8"	9.525	1/4"	-	1-3/4"	11.48	10.98	10.48	9.98
62050	SD-4	.4375	7/16"	11.113	1/4"	-	1-3/4"	16.68	15.95	15.23	14.50
62052	SD-4D	.4375	7/16"	11.113	1/4"	-	1-3/4"	16.68	15.95	15.23	14.50
62060	SD-5	.5000	1/2"	12.700	1/4"	-	1-3/4"	17.22	16.47	15.72	14.97
62061	SD-5A	.5000	1/2"	12.700	1/4"	-	1-3/4"	23.01	22.01	21.01	20.01
62062	SD-5D	.5000	1/2"	12.700	1/4"	-	1-3/4"	17.22	16.47	15.72	14.97
62070	SD-6	.6250	5/8"	15.875	1/4"	-	1-3/4"	19.24	18.40	17.57	16.73
62071	SD-6A	.6250	5/8"	15.875	1/4"	-	1-3/4"	39.82	38.09	36.36	34.63
62072	SD-6D	.6250	5/8"	15.875	1/4"	-	1-3/4"	19.24	18.40	17.57	16.73
62080	SD-7	.7500	3/4"	19.050	1/4"	-	1-3/4"	27.40	26.21	25.02	23.83
62082	SD-7D	.7500	3/4"	19.050	1/4"	-	1-3/4"	27.40	26.21	25.02	23.83
62090	SD-9	1.000	1"	25.400	1/4"	-	1-3/4"	50.82	48.61	46.40	44.19
62092	SD-9D	1.000	1"	25.400	1/4"	-	1-3/4"	50.82	48.61	46.40	44.19

Carbide Rotary Files - Egg Shape

Submicron Grain Carbide

A - Aluminum Cut

D - Double Cut

* - Solid Carbide

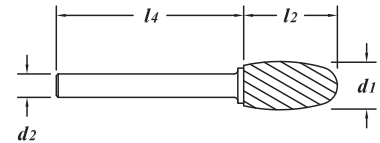

EDP#	TOOL #	$d1$ †		$d2$ Shank Diameter	$l2$ Flute Length	$l4$ Shank Length	1-11	12-24	25-49	50-100
		Decimal	Diameter							
63010	* SE-1	.2500	1/4"	6.350	1/4"	2"	11.56	11.06	10.55	10.05
63012	* SE-1D	.2500	1/4"	6.350	1/4"	3/8"	11.56	11.06	10.55	10.05
63020	SE-3	.3750	3/8"	9.525	1/4"	5/8"	16.05	15.36	14.66	13.96
63021	SE-3A	.3750	3/8"	9.525	1/4"	5/8"	23.26	22.25	21.24	20.23
63022	SE-3D	.3750	3/8"	9.525	1/4"	5/8"	16.05	15.36	14.66	13.96
63030	SE-5	.5000	1/2"	12.700	1/4"	7/8"	20.54	19.65	18.75	17.86
63031	SE-5A	.5000	1/2"	12.700	1/4"	7/8"	33.40	31.94	30.49	29.04
63032	SE-5D	.5000	1/2"	12.700	1/4"	7/8"	20.54	19.65	18.75	17.86
63040	SE-6	.6250	5/8"	15.875	1/4"	1"	30.16	28.85	27.54	26.23
63041	SE-6A	.6250	5/8"	15.875	1/4"	1"	49.55	47.40	45.24	43.09
63042	SE-6D	.6250	5/8"	15.875	1/4"	1"	30.16	28.85	27.54	26.23
63050	SE-7	.7500	3/4"	19.050	1/4"	1"	41.57	39.77	37.96	36.15
63052	SE-7D	.7500	3/4"	19.050	1/4"	1"	41.57	39.77	37.96	36.15

SF (1/4" Steel Shank)

Carbide Rotary Files - Tree-Radius Shape

Submicron Grain Carbide

A - Aluminum Cut

D - Double Cut

* - Solid Carbide

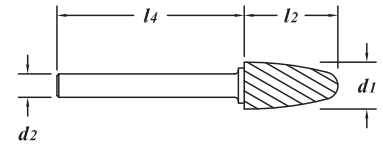

EDP#	TOOL #	$d1$ † Diameter		$d2$ Shank Diameter	$l2$ Flute Length	$l4$ Shank Length	1-11	12-24	25-49	50-100	
		Decimal	Metric								
64010	* SF-1	.2500	1/4"	6.350	1/4"	5/8"	2"	11.56	11.06	10.55	10.05
64011	* SF-1A	.2500	1/4"	6.350	1/4"	5/8"	2"	17.83	17.05	16.28	15.50
64012	* SF-1D	.2500	1/4"	6.350	1/4"	5/8"	2"	11.56	11.06	10.55	10.05
64020	SF-3	.3750	3/8"	9.525	1/4"	3/4"	1-3/4"	13.93	13.32	12.72	12.11
64021	SF-3A	.3750	3/8"	9.525	1/4"	3/4"	1-3/4"	22.46	21.48	20.51	19.53
64022	SF-3D	.3750	3/8"	9.525	1/4"	3/4"	1-3/4"	13.93	13.32	12.72	12.11
64030	SF-5	.5000	1/2"	12.700	1/4"	1"	1-3/4"	20.86	19.95	19.05	18.14
64031	SF-5A	.5000	1/2"	12.700	1/4"	1"	1-3/4"	31.79	30.40	29.02	27.64
64032	SF-5D	.5000	1/2"	12.700	1/4"	1"	1-3/4"	20.86	19.95	19.05	18.14
64040	SF-6	.6250	5/8"	15.875	1/4"	1"	1-3/4"	28.88	27.62	26.37	25.11
64041	SF-6A	.6250	5/8"	15.875	1/4"	1"	1-3/4"	44.19	42.27	40.35	38.43
64042	SF-6D	.6250	5/8"	15.875	1/4"	1"	1-3/4"	28.88	27.62	26.37	25.11
64050	SF-14	.7500	3/4"	19.050	1/4"	1-1/4"	1-3/4"	44.48	42.55	40.61	38.68
64052	SF-14D	.7500	3/4"	19.050	1/4"	1-1/4"	1-3/4"	44.48	42.55	40.61	38.68

Carbide Rotary Files - Tree-Pointed Shape

Submicron Grain Carbide

D - Double Cut

* - Solid Carbide

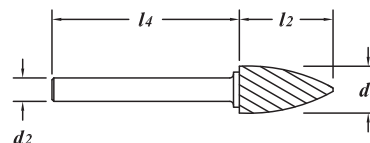

EDP#	TOOL #	$d1$ †		$d2$ Shank Diameter	$l2$ Flute Length	$l4$ Shank Length	1-11	12-24	25-49	50-100	
		Decimal	Diameter								Metric
65010	* SG-1	.2500	1/4"	6.350	1/4"	5/8"	2"	11.56	11.06	10.55	10.05
65012	* SG-1D	.2500	1/4"	6.350	1/4"	5/8"	2"	11.56	11.06	10.55	10.05
65020	SG-3	.3750	3/8"	9.525	1/4"	3/4"	1-3/4"	14.86	14.21	13.57	12.92
65022	SG-3D	.3750	3/8"	9.525	1/4"	3/4"	1-3/4"	14.86	14.21	13.57	12.92
65030	SG-13	.5000	1/2"	12.700	1/4"	3/4"	1-3/4"	19.90	19.03	18.17	17.30
65032	SG-13D	.5000	1/2"	12.700	1/4"	3/4"	1-3/4"	19.90	19.03	18.17	17.30
65040	SG-5	.5000	1/2"	12.700	1/4"	1"	1-3/4"	20.57	19.68	18.78	17.89
65042	SG-5D	.5000	1/2"	12.700	1/4"	1"	1-3/4"	20.57	19.68	18.78	17.89
65050	SG-6	.6250	5/8"	15.875	1/4"	1"	1-3/4"	28.88	27.62	26.37	25.11
65052	SG-6D	.6250	5/8"	15.875	1/4"	1"	1-3/4"	28.88	27.62	26.37	25.11
65060	SG-7	.7500	3/4"	19.050	1/4"	1"	1-3/4"	38.19	36.53	34.87	33.21
65062	SG-7D	.7500	3/4"	19.050	1/4"	1"	1-3/4"	38.19	36.53	34.87	33.21

SH (1/4" Steel Shank)

Carbide Rotary Files - Flame Shape

Submicron Grain Carbide

D - Double Cut

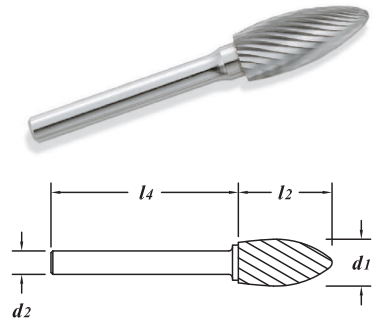

EDP#	TOOL #	d_1 † Diameter		d_2 Shank Diameter	l_2 Flute Length	l_4 Shank Length	1-11	12-24	25-49	50-100	
		Decimal	Metric								
66010	SH-2	.3125	5/16"	7.938	1/4"	3/4"	1-3/4"	14.12	13.51	12.89	12.28
66012	SH-2D	.3125	5/16"	7.938	1/4"	3/4"	1-3/4"	14.12	13.51	12.89	12.28
66020	SH-5	.5000	1/2"	12.700	1/4"	1-1/4"	1-3/4"	28.88	27.62	26.37	25.11
66022	SH-5D	.5000	1/2"	12.700	1/4"	1-1/4"	1-3/4"	28.88	27.62	26.37	25.11
66030	SH-6	.6250	5/8"	15.875	1/4"	1-7/16"	1-3/4"	37.86	36.21	34.57	32.92
66032	SH-6D	.6250	5/8"	15.875	1/4"	1-7/16"	1-3/4"	37.86	36.21	34.57	32.92
66040	SH-7	.7500	3/4"	19.050	1/4"	1-5/8"	1-3/4"	46.52	44.50	42.47	40.45
66042	SH-7D	.7500	3/4"	19.050	1/4"	1-5/8"	1-3/4"	46.52	44.50	42.47	40.45

Carbide Rotary Files - Taper Shape (60° Included Angle)

Submicron Grain Carbide

D - Double Cut

** - Solid Carbide/Double End

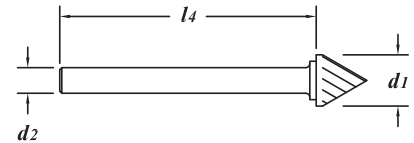

EDP#	TOOL #	$d1$ †		$d2$ Shank Diameter	$l4$ Shank Length	1-11	12-24	25-49	50-100	
		Decimal	Diameter							
67010	**SJ-1	.2500	1/4"	6.350	1/4"	1-11/16"	14.54	13.90	13.27	12.64
67012	**SJ-1D	.2500	1/4"	6.350	1/4"	1-11/16"	14.54	13.90	13.27	12.64
67020	SJ-3	.3750	3/8"	9.525	1/4"	1-3/4"	12.20	11.67	11.14	10.61
67022	SJ-3D	.3750	3/8"	9.525	1/4"	1-3/4"	12.20	11.67	11.14	10.61
67030	SJ-5	.5000	1/2"	12.700	1/4"	1-3/4"	15.04	14.39	13.73	13.08
67032	SJ-5D	.5000	1/2"	12.700	1/4"	1-3/4"	15.04	14.39	13.73	13.08
67040	SJ-6	.6250	5/8"	15.875	1/4"	1-3/4"	20.04	19.17	18.30	17.43
67042	SJ-6D	.6250	5/8"	15.875	1/4"	1-3/4"	20.04	19.17	18.30	17.43
67050	SJ-7	.7500	3/4"	19.050	1/4"	1-3/4"	26.30	25.16	24.01	22.87
67052	SJ-7D	.7500	3/4"	19.050	1/4"	1-3/4"	26.30	25.16	24.01	22.87

SK (1/4" Steel Shank)

Carbide Rotary Files - Taper Shape (90° Included Angle)

Submicron Grain Carbide

D - Double Cut

** - Solid Carbide/Double End

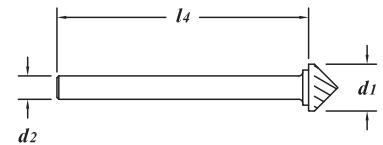

EDP#	TOOL #	$d1$ †		$d2$ Shank Diameter	$l4$ Shank Length	1-11	12-24	25-49	50-100	
		Decimal	Diameter							
68010	**SK-1	.2500	1/4"	6.350	1/4"	1-11/16"	14.54	13.90	13.27	12.64
68012	**SK-1D	.2500	1/4"	6.350	1/4"	1-11/16"	14.54	13.90	13.27	12.64
68020	SK-3	.3750	3/8"	9.525	1/4"	1-3/4"	12.20	11.67	11.14	10.61
68022	SK-3D	.3750	3/8"	9.525	1/4"	1-3/4"	12.20	11.67	11.14	10.61
68030	SK-5	.5000	1/2"	12.700	1/4"	1-3/4"	15.04	14.39	13.73	13.08
68032	SK-5D	.5000	1/2"	12.700	1/4"	1-3/4"	15.04	14.39	13.73	13.08
68040	SK-6	.6250	5/8"	15.875	1/4"	1-3/4"	20.04	19.17	18.30	17.43
68042	SK-6D	.6250	5/8"	15.875	1/4"	1-3/4"	20.04	19.17	18.30	17.43
68050	SK-7	.7500	3/4"	19.050	1/4"	1-3/4"	26.30	25.16	24.01	22.87
68052	SK-7D	.7500	3/4"	19.050	1/4"	1-3/4"	26.30	25.16	24.01	22.87
68070	SK-9	1.000	1"	25.400	1/4"	1-3/4"	42.18	40.35	38.51	36.68
68072	SK-9D	1.000	1"	25.400	1/4"	1-3/4"	42.18	40.35	38.51	36.68

Carbide Rotary Files - Cone-Radius Shape (14° Included Angle)

Submicron Grain Carbide

A - Aluminum Cut

D - Double Cut

* - Solid Carbide

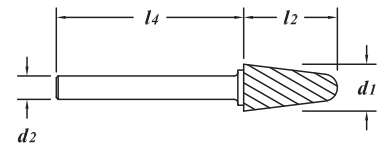

EDP#	TOOL #	$d1$ † Diameter		$d2$ Shank Diameter	$l2$ Flute Length	$l4$ Shank Length	1-11	12-24	25-49	50-100	
		Decimal	Metric								
69010	* SL-1	.2500	1/4"	6.350	1/4"	5/8"	2"	11.56	11.06	10.55	10.05
69012	* SL-1D	.2500	1/4"	6.350	1/4"	5/8"	2"	11.56	11.06	10.55	10.05
69020	SL-2	.3125	5/16"	7.938	1/4"	7/8"	1-3/4"	13.80	13.20	12.60	12.00
69022	SL-2D	.3125	5/16"	7.938	1/4"	7/8"	1-3/4"	13.80	13.20	12.60	12.00
69030	SL-3	.3750	3/8"	9.525	1/4"	1-1/16"	1-3/4"	16.36	15.65	14.94	14.23
69031	SL-3A	.3750	3/8"	9.525	1/4"	1-1/16"	1-3/4"	27.27	26.08	24.90	23.71
69032	SL-3D	.3750	3/8"	9.525	1/4"	1-1/16"	1-3/4"	16.36	15.65	14.94	14.23
69040	SL-4	.5000	1/2"	12.700	1/4"	1-1/8"	1-3/4"	19.90	19.03	18.17	17.30
69041	SL-4A	.5000	1/2"	12.700	1/4"	1-1/8"	1-3/4"	33.79	32.32	30.85	29.38
69042	SL-4D	.5000	1/2"	12.700	1/4"	1-1/8"	1-3/4"	19.90	19.03	18.17	17.30
69050	SL-5	.6250	5/8"	15.875	1/4"	1-3/16"	1-3/4"	39.15	37.44	35.74	34.04
69051	SL-5A	.6250	5/8"	15.875	1/4"	1-3/16"	1-3/4"	53.30	50.99	48.67	46.35
69052	SL-5D	.6250	5/8"	15.875	1/4"	1-3/16"	1-3/4"	39.15	37.44	35.74	34.04
69060	SL-7	.7500	3/4"	19.050	1/4"	1-1/2"	1-3/4"	51.67	49.42	47.18	44.93
69062	SL-7D	.7500	3/4"	19.050	1/4"	1-1/2"	1-3/4"	51.67	49.42	47.18	44.93

SM (1/4" Steel Shank)

Carbide Rotary Files - Cone Flat Shape (no radius)

Submicron Grain Carbide

D - Double Cut

* - Solid Carbide

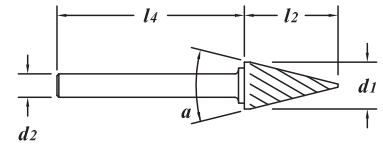

EDP#	TOOL #	$d1$ †		$d2$ Shank Diameter	a Included Angle	$l2$ Flute Length	$l4$ Shank Length	1-11	12-24	25-49	50-100	
		Decimal	Diameter									Metric
70010	* SM-1	.2500	1/4"	6.350	1/4"	22°	1/2"	2"	11.56	11.06	10.55	10.05
70012	* SM-1D	.2500	1/4"	6.350	1/4"	22°	1/2"	2"	11.56	11.06	10.55	10.05
70020	SM-4	.3750	3/8"	9.525	1/4"	28°	5/8"	1-3/4"	16.36	15.65	14.94	14.23
70022	SM-4D	.3750	3/8"	9.525	1/4"	28°	5/8"	1-3/4"	16.36	15.65	14.94	14.23
70030	SM-5	.5000	1/2"	12.700	1/4"	28°	7/8"	1-3/4"	20.54	19.65	18.75	17.86
70032	SM-5D	.5000	1/2"	12.700	1/4"	28°	7/8"	1-3/4"	20.54	19.65	18.75	17.86
70040	SM-6	.6250	5/8"	15.875	1/4"	31°	1"	1-3/4"	27.28	26.09	24.91	23.72
70042	SM-6D	.6250	5/8"	15.875	1/4"	31°	1"	1-3/4"	27.28	26.09	24.91	23.72



Carbide Rotary Files - Inverted Cone Shape

Submicron Grain Carbide

D - Double Cut

* - Solid Carbide

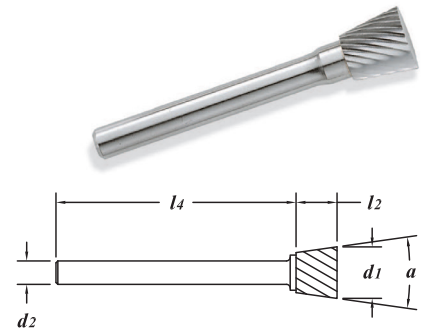

EDP#	TOOL #	$d1$ †		$d2$ Shank Diameter	a Included Angle	$l2$ Flute Length	$l4$ Shank Length	1-11	12-24	25-49	50-100	
		Decimal	Diameter									Metric
71010	* SN-1	.2500	1/4"	6.350	1/4"	10°	5/16"	2"	11.56	11.06	10.55	10.05
71012	* SN-1D	.2500	1/4"	6.350	1/4"	10°	5/16"	2"	11.56	11.06	10.55	10.05
71020	SN-2	.3750	3/8"	9.525	1/4"	13°	3/8"	1-3/4"	14.42	13.79	13.17	12.54
71022	SN-2D	.3750	3/8"	9.525	1/4"	13°	3/8"	1-3/4"	14.42	13.79	13.17	12.54
71030	SN-3	.5000	1/2"	12.700	1/4"	16°	1/2"	1-3/4"	19.90	19.03	18.17	17.30
71032	SN-3D	.5000	1/2"	12.700	1/4"	16°	1/2"	1-3/4"	19.90	19.03	18.17	17.30



3/16" Diameter (3/16" Shank)

Solid Carbide Rotary Files

Submicron Grain Carbide

D - Double Cut

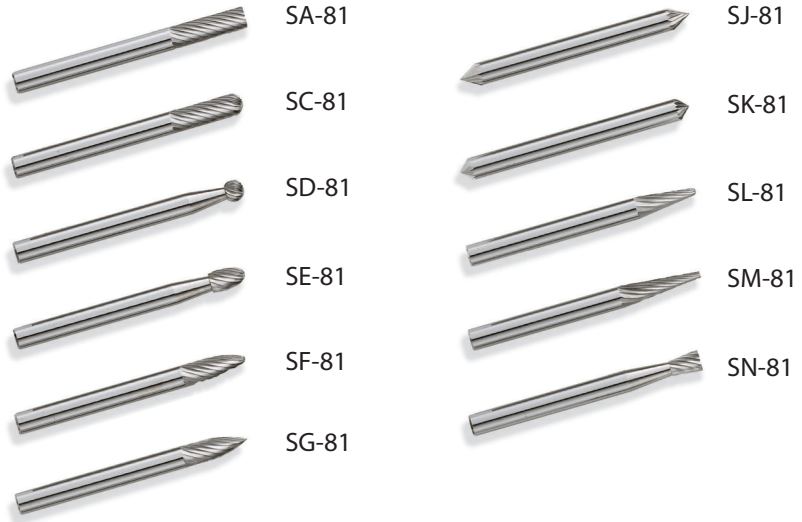

EDP#	TOOL #	d_1 † Diameter		l_1 Overall Length	a Included Angle	l_2 Flute Length	1-11	12-24	25-49	50-100	
		Decimal	Metric								
72010	SA-81	.1875	3/16"	4.763	2"	-	5/8"	12.64	12.09	11.54	10.99
72012	SA-81D	.1875	3/16"	4.763	2"	-	5/8"	12.64	12.09	11.54	10.99
72020	SC-81	.1875	3/16"	4.763	2"	-	5/8"	12.64	12.09	11.54	10.99
72030	SD-81	.1875	3/16"	4.763	2"	-	-	12.64	12.09	11.54	10.99
72032	SD-81D	.1875	3/16"	4.763	2"	-	-	12.64	12.09	11.54	10.99
72040	SE-81	.1875	3/16"	4.763	2"	-	9/32"	12.64	12.09	11.54	10.99
72042	SE-81D	.1875	3/16"	4.763	2"	-	9/32"	12.64	12.09	11.54	10.99
72050	SF-81	.1875	3/16"	4.763	2"	-	1/2"	12.64	12.09	11.54	10.99
72052	SF-81D	.1875	3/16"	4.763	2"	-	1/2"	12.64	12.09	11.54	10.99
72060	SG-81	.1875	3/16"	4.763	2"	-	1/2"	12.64	12.09	11.54	10.99
72062	SG-81D	.1875	3/16"	4.763	2"	-	1/2"	12.64	12.09	11.54	10.99
72070	SJ-81	.1875	3/16"	4.763	2"	60°	-	12.64	12.09	11.54	10.99
72072	SJ-81D	.1875	3/16"	4.763	2"	60°	-	12.64	12.09	11.54	10.99
72080	SK-81	.1875	3/16"	4.763	2"	90°	-	12.64	12.09	11.54	10.99
72082	SK-81D	.1875	3/16"	4.763	2"	90°	-	12.64	12.09	11.54	10.99
72090	SL-81	.1875	3/16"	4.763	2"	14°	1/2"	12.64	12.09	11.54	10.99
72092	SL-81D	.1875	3/16"	4.763	2"	14°	1/2"	12.64	12.09	11.54	10.99
72100	SM-81	.1875	3/16"	4.763	2"	12°	5/8"	12.64	12.09	11.54	10.99
72110	SN-81	.1875	3/16"	4.763	2"	10°	1/4"	12.64	12.09	11.54	10.99
72112	SN-81D	.1875	3/16"	4.763	2"	10°	1/4"	12.64	12.09	11.54	10.99

Carbide Rotary Files

Submicron Grain Carbide
D - Double Cuts

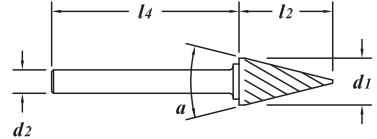
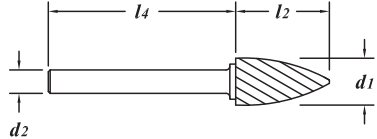

EDP#	TOOL #	$d1$ † Diameter		$d2$ Shank Diameter	a Included Angle	$l2$ Flute Length	$l4$ Shank Length	1-11	12-24	25-49	50-100	
		Decimal	Metric									
73010	SA-51	.2500	1/4"	6.350	1/8"	-	1/2"	1-1/2"	12.06	11.54	11.01	10.49
73012	SA-51D	.2500	1/4"	6.350	1/8"	-	1/2"	1-1/2"	12.06	11.54	11.01	10.49
73020	SB-51	.2500	1/4"	6.350	1/8"	-	3/16"	1-1/2"	12.06	11.54	11.01	10.49
73022	SB-51D	.2500	1/4"	6.350	1/8"	-	3/16"	1-1/2"	12.06	11.54	11.01	10.49
73030	SC-51	.2500	1/4"	6.350	1/8"	-	1/2"	1-1/2"	12.06	11.54	11.01	10.49
73032	SC-51D	.2500	1/4"	6.350	1/8"	-	1/2"	1-1/2"	12.06	11.54	11.01	10.49
73040	SD-51	.2500	1/4"	6.350	1/8"	-	-	1-1/2"	12.06	11.54	11.01	10.49
73042	SD-51D	.2500	1/4"	6.350	1/8"	-	-	1-1/2"	12.06	11.54	11.01	10.49
73050	SE-51	.2500	1/4"	6.350	1/8"	-	3/8"	1-1/2"	12.06	11.54	11.01	10.49
73052	SE-51D	.2500	1/4"	6.350	1/8"	-	3/8"	1-1/2"	12.06	11.54	11.01	10.49
73060	SF-51	.2500	1/4"	6.350	1/8"	-	1/2"	1-1/2"	12.06	11.54	11.01	10.49
73062	SF-51D	.2500	1/4"	6.350	1/8"	-	1/2"	1-1/2"	12.06	11.54	11.01	10.49
73070	SG-51	.2500	1/4"	6.350	1/8"	-	1/2"	1-1/2"	12.06	11.54	11.01	10.49
73072	SG-51D	.2500	1/4"	6.350	1/8"	-	1/2"	1-1/2"	12.06	11.54	11.01	10.49
73080	SM-51	.2500	1/4"	6.350	1/8"	22°	1/2"	1-1/2"	12.06	11.54	11.01	10.49
73082	SM-51D	.2500	1/4"	6.350	1/8"	22°	1/2"	1-1/2"	12.06	11.54	11.01	10.49
73090	SN-51	.2500	1/4"	6.350	1/8"	10°	1/4"	1-1/2"	12.06	11.54	11.01	10.49
73092	SN-51D	.2500	1/4"	6.350	1/8"	10°	1/4"	1-1/2"	12.06	11.54	11.01	10.49

CAD drawings representative for dimension placement

1/8" Diameter (1/8" Shank)

Solid Carbide Rotary Files

Submicron Grain Carbide

D - Double Cut

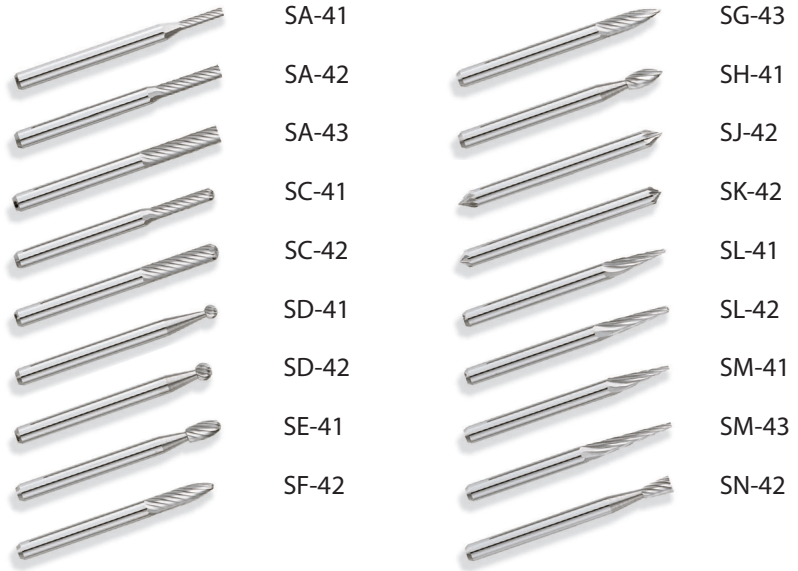

EDP#	TOOL #	$d1$ †		$l1$ Overall Length	a Included Angle	$l2$ Flute Length	1-11	12-24	25-49	50-100	
		Decimal	Metric								
74010	SA-41	.0625	1/16"	1.588	1-1/2"	-	1/4"	7.14	6.83	6.52	6.21
74012	SA-41D	.0625	1/16"	1.588	1-1/2"	-	1/4"	7.14	6.83	6.52	6.21
74020	SA-42	.0938	3/32"	2.383	1-1/2"	-	7/16"	7.14	6.83	6.52	6.21
74022	SA-42D	.0938	3/32"	2.383	1-1/2"	-	7/16"	7.14	6.83	6.52	6.21
74030	SA-43	.1250	1/8"	3.175	1-1/2"	-	9/16"	7.14	6.83	6.52	6.21
74032	SA-43D	.1250	1/8"	3.175	1-1/2"	-	9/16"	7.14	6.83	6.52	6.21
74040	SC-41	.0938	3/32"	2.383	1-1/2"	-	7/16"	7.14	6.83	6.52	6.21
74042	SC-41D	.0938	3/32"	2.383	1-1/2"	-	7/16"	7.14	6.83	6.52	6.21
74050	SC-42	.1250	1/8"	3.175	1-1/2"	-	9/16"	7.14	6.83	6.52	6.21
74052	SC-42D	.1250	1/8"	3.175	1-1/2"	-	9/16"	7.14	6.83	6.52	6.21
74060	SD-41	.0938	3/32"	2.383	1-1/2"	-	-	7.14	6.83	6.52	6.21
74062	SD-41D	.0938	3/32"	2.383	1-1/2"	-	-	7.14	6.83	6.52	6.21
74070	SD-42	.1250	1/8"	3.175	1-1/2"	-	-	7.14	6.83	6.52	6.21
74072	SD-42D	.1250	1/8"	3.175	1-1/2"	-	-	7.14	6.83	6.52	6.21
74080	SE-41	.1250	1/8"	3.175	1-1/2"	-	7/32"	7.14	6.83	6.52	6.21
74082	SE-41D	.1250	1/8"	3.175	1-1/2"	-	7/32"	7.14	6.83	6.52	6.21
74090	SF-42	.1250	1/8"	3.175	1-1/2"	-	1/2"	7.14	6.83	6.52	6.21
74092	SF-42D	.1250	1/8"	3.175	1-1/2"	-	1/2"	7.14	6.83	6.52	6.21
74100	SG-43	.1250	1/8"	3.175	1-1/2"	-	3/8"	7.14	6.83	6.52	6.21
74102	SG-43D	.1250	1/8"	3.175	1-1/2"	-	3/8"	7.14	6.83	6.52	6.21
74110	SH-41	.1250	1/8"	3.175	1-1/2"	-	1/4"	7.14	6.83	6.52	6.21
74112	SH-41D	.1250	1/8"	3.175	1-1/2"	-	1/4"	7.14	6.83	6.52	6.21
74120	SJ-42	.1250	1/8"	3.175	1-1/2"	60°	-	7.14	6.83	6.52	6.21
74122	SJ-42D	.1250	1/8"	3.175	1-1/2"	60°	-	7.14	6.83	6.52	6.21
74130	SK-42	.1250	1/8"	3.175	1-1/2"	90°	-	7.14	6.83	6.52	6.21
74132	SK-42D	.1250	1/8"	3.175	1-1/2"	90°	-	7.14	6.83	6.52	6.21
74140	SL-41	.1250	1/8"	3.175	1-1/2"	8°	3/8"	7.14	6.83	6.52	6.21
74142	SL-41D	.1250	1/8"	3.175	1-1/2"	8°	3/8"	7.14	6.83	6.52	6.21
74150	SL-42	.1250	1/8"	3.175	1-1/2"	8°	1/2"	7.14	6.83	6.52	6.21
74152	SL-42D	.1250	1/8"	3.175	1-1/2"	8°	1/2"	7.14	6.83	6.52	6.21
74160	SM-41	.1250	1/8"	3.175	1-1/2"	12°	3/8"	7.14	6.83	6.52	6.21
74162	SM-41D	.1250	1/8"	3.175	1-1/2"	12°	3/8"	7.14	6.83	6.52	6.21
74170	SM-43	.1250	1/8"	3.175	1-1/2"	7°	5/8"	7.14	6.83	6.52	6.21
74172	SM-43D	.1250	1/8"	3.175	1-1/2"	7°	5/8"	7.14	6.83	6.52	6.21
74180	SN-42	.1250	1/8"	3.175	1-1/2"	10°	3/16"	7.14	6.83	6.52	6.21
74182	SN-42D	.1250	1/8"	3.175	1-1/2"	10°	3/16"	7.14	6.83	6.52	6.21